

Fibre Cement Slates



Fixing Guide

Site Working

CemBrit Slates can be cut using the traditional method of scoring with a scribe and breaking over a straight edge. Additional fixing holes should be drilled using a 4.5mm masonry drill and must be positioned not less than 20mm from the edge of the slate. Slates can be cut using a handsaw, but the use of angle grinders is not recommended due to nuisance dust levels. After cutting and drilling, all dust must be cleaned from the slate to avoid subsequent staining.

Underlay

Select a suitable underlay in accordance with BS 5534: Part 1: 1990. Where the underlay is draped over the rafters it should be reinforced type 1f to BS 747. Underlay must be securely fixed over the rafters with minimum vertical laps of 100mm. Horizontal laps should be a minimum of 150mm for roof pitches below 35° and 100mm at 35° and above. Ensure the underlay drains freely into the gutter and does not obstruct the flow of air through ventilators. Avoid 'ponding' behind the fascia with the use of a tilting fillet.

Battens

Battens should be of treated softwood and be free of decay, insect attack, splits, shakes or knot holes greater in size than one third of the width of the batten. Battens should be of sufficient length to be supported at each end and intermediately by a total of three rafters. Fixing of the battens should be in accordance with BS 8000: Part 6: 1990. Select the batten size from the Table below.

Rafter spacing	Batten size
up to 450mm	25 x 38mm
451 - 600mm	25 x 50mm

Setting out

Roofs should be set out with battens fixed to the appropriate gauge. The gauge can be calculated using the formula:

$$\text{Gauge} = \frac{\text{Length of slate} - \text{lap}}{2}$$

Eaves slates should overhang the gutter by 50mm and the verge overhang should not exceed 50mm. Care should be taken to avoid the use of slates less than 125mm wide or of small shaped pieces which may be difficult to fix.

Fixing

Slates must be fixed in accordance with BS 5534: Part 1: 1990, and BS 8000: Part 6: 1990. The slates should be laid with a broken bond, in regular horizontal courses with tails aligned. Slates are to be centre nailed using two, 2.65mm x 30mm long copper nails. The tail is restrained using a copper disc rivet (20mm base with 20 x 2mm pin). Leave a minimum of 3mm gap between slates. Slates in excess of a standard width should be fixed with three nails and two disc rivets, maintaining the normal nailing pattern. All nails should be driven home firmly but not too tightly.

With straight cover slates the following fixing sequence is recommended:

1. Slates for first under eaves course.

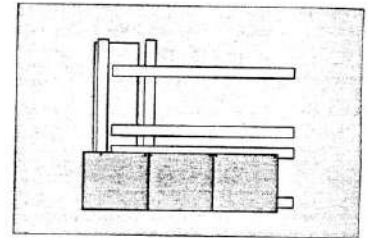

2. Second under eaves course. Use a slate and a half width to the verge. Before fixing it should be drilled as illustrated. This allows for fixing of a copper disc rivet to the first full-size course.

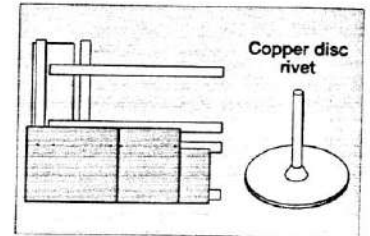

3. First full size slate course. It is advisable to utilise a vertical batten at the verge and at intersections; for example, each side of hips and valleys.

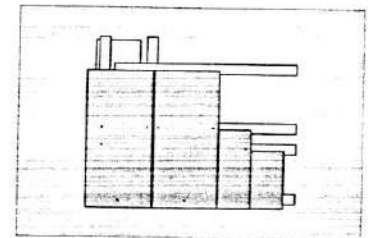

4. Work across and up the roof. Whole slates should trim to verges, hips valleys and ridges. Double slates are available for cutting at hips, valleys and verges.

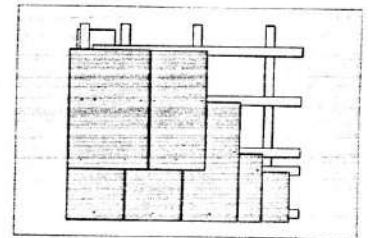

Eaves

The eaves course must be supported by the fascia board and/or a continuous tilting fillet. The tilting fillet serves to prevent water being trapped behind the fascia and to commence the correct layering of the slates. The leading edge of the fascia/tilting fillet should be 8-15mm above the top of the general slating batten level. Ensure that the underlay overhangs the fascia sufficiently to discharge into the gutter. Where an eaves ventilator has been used, ensure that the underlay does not obstruct the passage of air into the roof void.

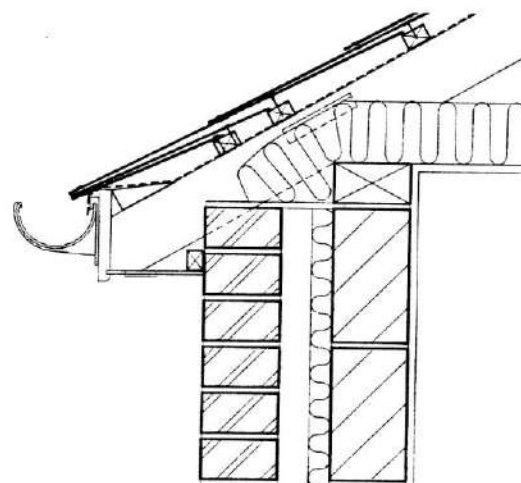

Verges

Slates should overhang at the verge by not more than 50mm. A slate and a half should be used in alternate courses to maintain the bond. Slate and a half slates should be drilled to accept three nails and two disc rivets. Position the first nail and rivet 50mm from the outer edge of the slate and the remaining nails and rivet as for the standard slates. The undercloak should be butt jointed, nailed at not less than 300mm centres and well bedded in mortar, rough side up. The verge slates are bedded to the undercloak with a 1:3 cement:sand, mortar, pigmented as required. An additive may be used to prevent shrinkage. Do not cover the edge of the slates with mortar. Where a proprietary verge closer or dry verge is used, refer to the specific fixing instructions.

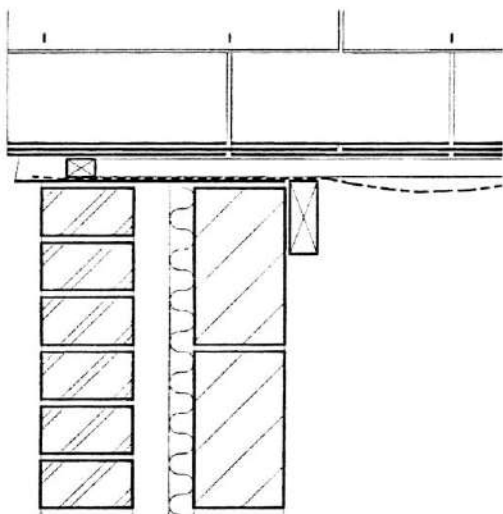

Valleys

Underlay and slating battens should be cut and fixed so that they bear at least 50mm on to each valley board. Triangular valley fillets, to match the thickness of the slating battens, to be fixed to ensure sufficient valley width. A lead gutter lining (minimum Code 4) to be fixed over the valley boards and dressed on to the valley fillets. Form a welted edge on the inside edges of the gutter lining, position the underlay over the welted edges of the valley and trim 40mm beyond the fillet. Slates should be cut on the rake so that the tail overhangs the valley fillet by 50mm and leaves a minimum 100mm wide clear gutter. Double slates should be used to provide sufficient width at the tail of each slate. Coat lead with patination oil.

Long valleys, Low pitches and valleys with unequal roof pitches on either side require special consideration. For further information refer to the 'Lead Sheet Manual'.

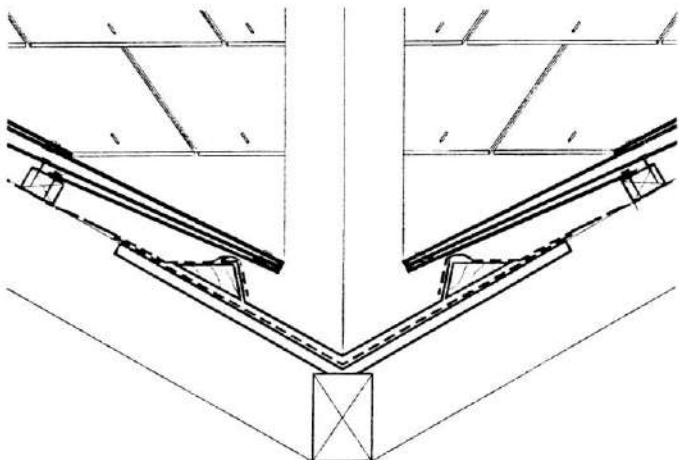

Close mitred hips

Dress additional underlay along the hip rafter with a 300mm overlap on each side. Fix slating battens to hip rafter and align on each slope. If pitches either side vary then the gauge must be set out on the shallower pitch. Double width slates are close cut and mitred to the line of the hip and site drilled with three nail and two rivet holes. Insert a chevron shaped Code 3 lead soaker at every course up the hip. Soakers should have a minimum girth of 300mm and a length equal to: gauge + lap + 30mm. Fix the slates with three nails and two disc rivets with the third nail either into a continuous batten either side of the hip, or an additional batten parallel and central to the slating batten (fixed to at least two rafters on each side of the hip). Consideration should be given to the provision of extra mechanical tail fixings on hip slates, particularly in exposed situations. Close mitred hips are not recommended at rafter pitches below $27\frac{1}{2}^{\circ}$.

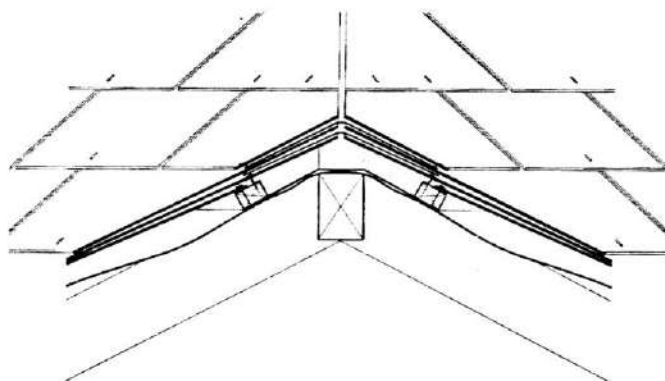

Abutments

Where slates abut walls, chimneys and dormer windows etc. they should be close cut and a Code 3 lead soaker inserted in each course. The length of the soaker should be equal to: gauge + lap + 30mm, thus allowing the head of the soaker to be nailed to the batten. Ensure that the bottom edge of the soaker is fixed 10mm back from the edge of the next slate. The minimum girth to be 175mm, bent to provide a 75mm upstand. Soakers should be treated with patination oil before fixing. Fix a cover flashing over the soaker upstands, welt the top edge and secure with lead wedges into the brickwork by a minimum of 25mm. Point with mortar. Treat cover flashings with patination oil as soon as completed.

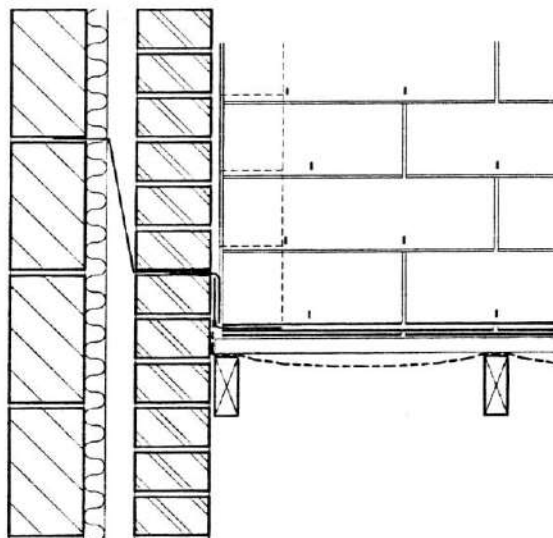

Ridge

Fix underlay along the ridge to overlap opposite pitches by 300mm, except in the case of ventilated ridge where a clear opening of 30mm must be maintained. Fix the top slating battens to suit gauge of slates and, if required, position additional battens to receive screw fixings for Duraplast or fibre cement ridges. The slates in the top courses at the ridge should be of such a length and gauge as to ensure that the lap is maintained.

Duraplast or fibre cement ridges are secured with 51 x 6.3mm Sela screws 50mm up from the bottom edge of the ridge. All joints should be sealed using a butyl strip. Locate and position sockets away from the prevailing weather direction.

For concrete or clay ridges, edge bed in, mortar and solid bed all joints and end ridges. Finish bedding and pointing neatly. Mortar should be a 1:3, cement:sand mix with pigments and plasticizers added as required.

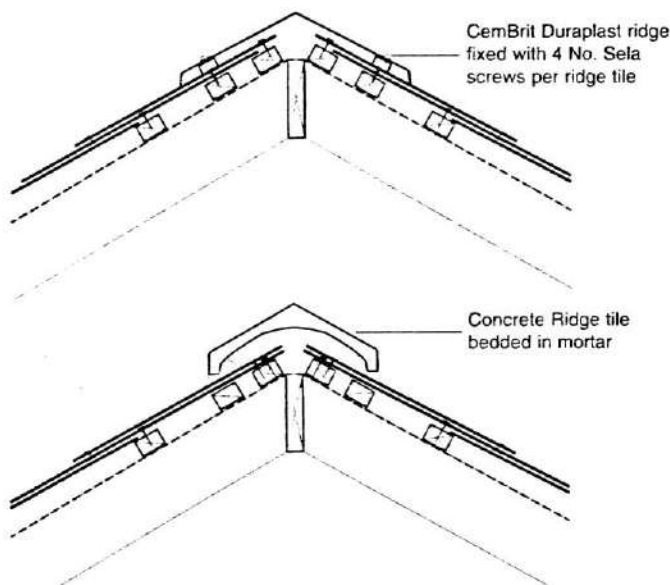

Vertical slating

Vertical slating procedures are generally the same as those used for pitched roofs. Slates are fixed to battens, ideally fixed to counter battens. The use of counter battens fixed to the wall face will reduce the amount of nailing to a solid wall. At sloping verges the slates should be splay cut avoiding the use of small triangular pieces of slate. At quoins and other vertical angles, the slates should be mitred and laid over lead soakers as with a close mitred hip.

Low pitches

When the rafter pitch is below the recommended minimum the roof must be constructed with a fully supported waterproof underlay, providing an uninterrupted drainage path to the eaves. Specific advice is available on request.

Ventilation

All buildings must be ventilated to comply with the requirements of current Building Regulations in order to prevent condensation within the roof, or the roof void. There is no obligation to adopt a particular solution to meet the requirements. We recommend that consideration is given to the specific roof construction and an appropriate solution is adopted using slate vents and eaves and ridge ventilators as required. Particular attention should be given to the ventilation of a 'Warm Roof' (where the insulation is at rafter level). Further advice is available on request.

Leadwork

Lead should comply with the requirements of BS 1178 and its thickness should be not less than the following:

Valleys:	Code 4 (1.80mm thick)
Gutters:	Code 5 (2.24mm thick)
Flashings:	Code 4 (1.80mm thick)
Soakers:	Code 3 (1.32mm thick)
Saddles:	Code 4 (1.80mm thick)

Water run-off from leadwork is likely to stain the slates. To avoid this, apply patination oil to the lead immediately after fixing.

Further information on leadwork is available from:
Lead Sheet Association: Tel (01892) 513351.

Storage

It is important that slates are kept dry, otherwise there is a risk that efflorescence and staining will occur as a result of water accumulating between the slate surfaces. Where slates are stored inside a building, the cardboard and polythene hoods should remain as a temporary cover. When slates have to be stored outside for short periods, the polythene hood should be completely removed to prevent condensation forming inside the pack. Ensure that slates are stored clear of the ground and covered completely with a tarpaulin. Air should be allowed to circulate freely around and through the stacks. Do not load the roof with more slates than can be laid during the working day.

Safety

It is recommended that during supply, handling and fixing of CemBrit slates, all relevant Safety and Construction Regulations, Codes of Practice and British Standards are complied with. These include The Construction (General Provisions) Regulations 1961, The Construction (Lifting Operations) Regulations 1961, The Construction (Working Places) Regulations 1966, The Construction (Health and Welfare) Regulations 1966 and The Health and Safety at Work etc, Act 1974. This list is not to be considered as exhaustive.



CemBrit Building Products Limited
Hamard House, Cardiff Road
Barry, CF63 2BE

Telephone: Barry (01446) 742095
Fax: Barry (01446) 721041